

ROBOCUT SYSTEM COMPUTER TRIMMER RCT

EASY OPERATION BY COLOR MONITOR DISPLAY

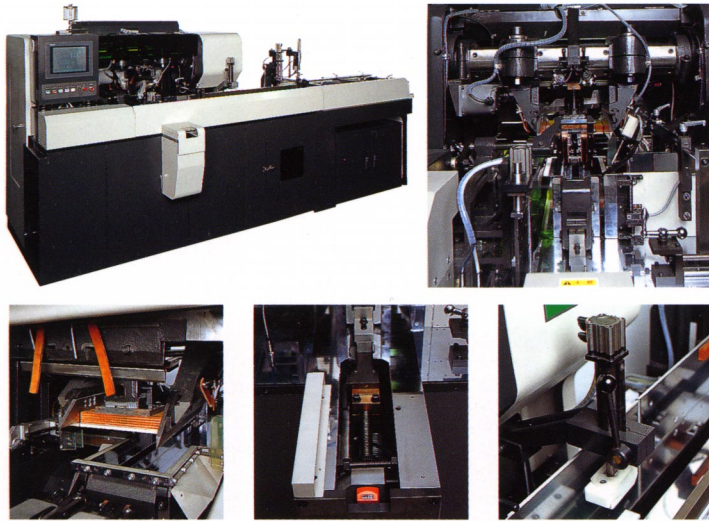

HIGH QUALITY, HIGH ACCURACY AND HIGH PERFORMANCE

EASY CHANGE THE CLAMP PLATE

Possible to rapid change the clamp plate without any tools.

LM Guide

Smooth and long life by Linear Motion Slide Way.

FEEDER

Catched books are carried by air sylinder unit.

INVERTER UNIT

Running speed is adjustable steplessly from 20prm to 50prm.

OPERATION BY TOUCH SCREEN

COLOR GRAPHIC OPERATION PANEL

10inch Flat color screen.

VERY EASY OPERATION IN STANDARD

Ability to select standard, A6, B6, A5, B5, A4 and B4 with touch.

MONITORING MESSAGE

Screen shows wrong (content, place and procedure) with photos and writing.

FUNCTION OF MESSAGE

Screen shows procedure of operation, set up and enter the data.



SPECIFICATIONS

Untrimmed size	max. 310x380mm
Trimmed size	min. 101x148mm max. 270x364mm
Height of pile	min. 10mm max. 140mm (under A4)
Speed	min. 20rpm max. 50rpm
Total power required	10kw
Net weight	4500kg

MEASUREMENT

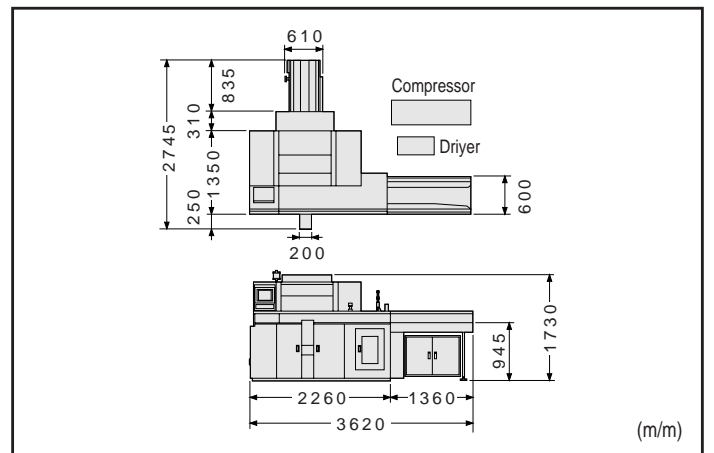

ITOTEC CO.,LTD

Funada No.10, Inuyama 484, Aichi-pref, Japan.
Phon : 81-568-67-5311
Telex : 4485158 ITOH J
Fax : 81-568-68-0495