



# eRC SERIES

**PREPARATION FOR COMPLYING WITH CIP4  
HAS BEEN COMPLETED**



Now revolution of the print workflow attracts attention. Information control linking the design, prepress, press and postpress has potentials of generating new values. Itotec caught near-future cutting scenes and finished preparation for complying with CIP4 at the earliest timing. eRC has superior operability and extendable LCD touch panel to make it possible to work according to the future requirements.

# MECHANICAL FEATURES AND STANDARD



## eRC SERIES

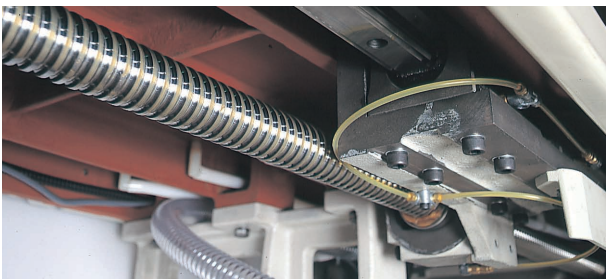

### BALL BEARING SCREW AND L.M.GUIDE

A combination of ball bearing screw and linear motion slide way for the back gauge ensures smooth and uniform movement even at low speed, sensitive and correct movement corresponding to input and superb durability.



### CENTRAL LUBRICATION SYSTEM

All of major oiling points are lubricated by the central lubrication pump.



### SHEAR BOLT (SAFETY BOLT)

Should the knife strike a hard material, shear bolts are broken to avoid serious damage to the machine.

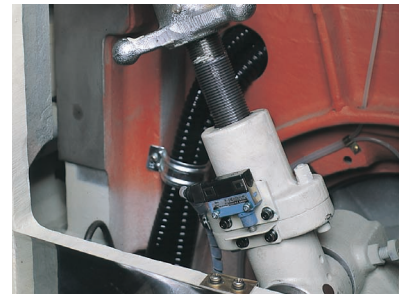

### MAGNETIC CLUTCH AND BRAKE

The clutch is of spring closing type which does not drive the knife' even at a sudden power suspension and is free from the conventional carbon brush troubles. (No carbon brush is used.)

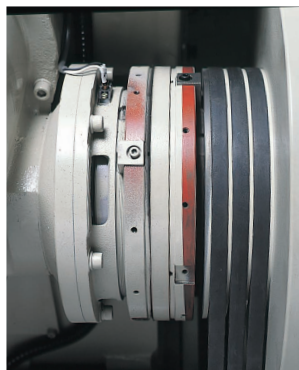

### MANY OPTIONAL UNITS

Robo-trim, inverter unit and other optional units manufactured to meet various requirements such as quality, operability and power saving are prepared.

# EQUIPMENT

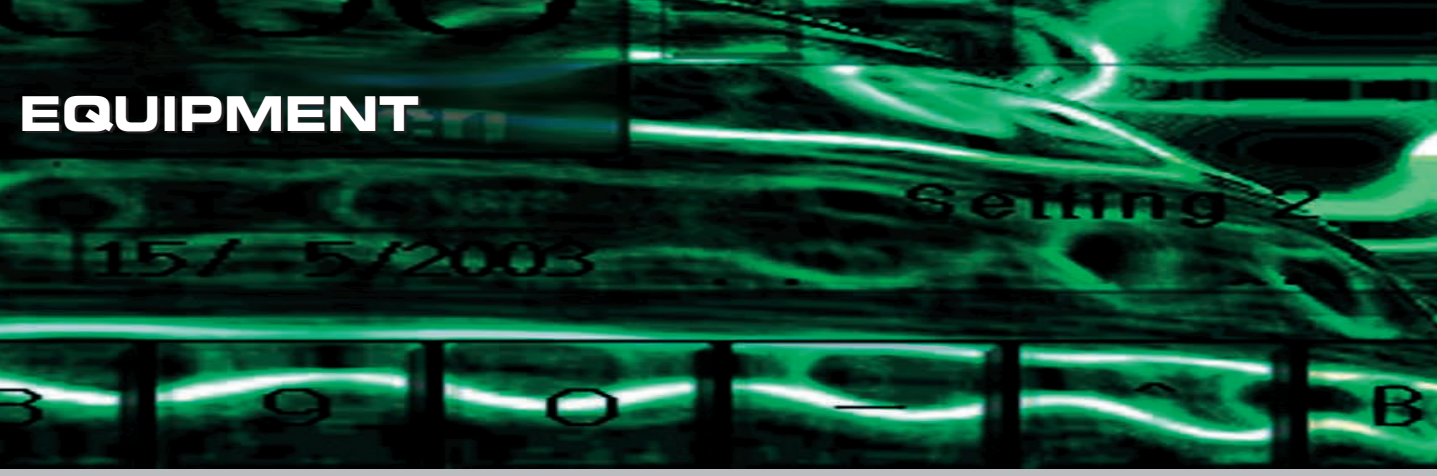

## KNIFE DRIVE DOUBLE-ENDED PULL

For an even cut from end to end and excellent all-round knife-cutting performance, only the double-ended pull system can deliver the power and precision.



## PHOTO-ELECTRIC BEAMS SAFETY GUARD

A set of infra-red light beams is projected in front of the cutting zone just above the table to avoid accident.



## AIR TABLE WITH CHROME-PLATING

The built-in air-table enables the operator to efficiently manipulate heavy and bulky stock with ease. The chromed table gathers no rust.

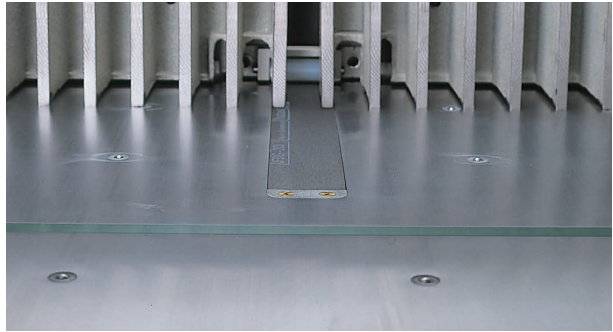

## SLOT CLOSING TAPE

A slot closing tape covers the slot (Groove) in the center of the main table to avoid trapping of paper and dust falling onto the ball bearing screw.

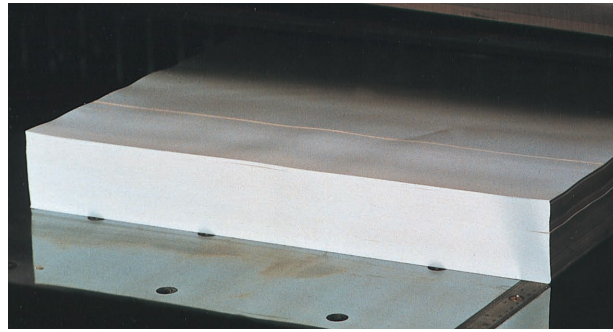

## OPTICAL CUTTING LINE

An optical cutting line is illuminated across the knife width. Operator can memorize the cutting data without descending the clamp.

# FEATURES OF eRC MICRO COMPUTER

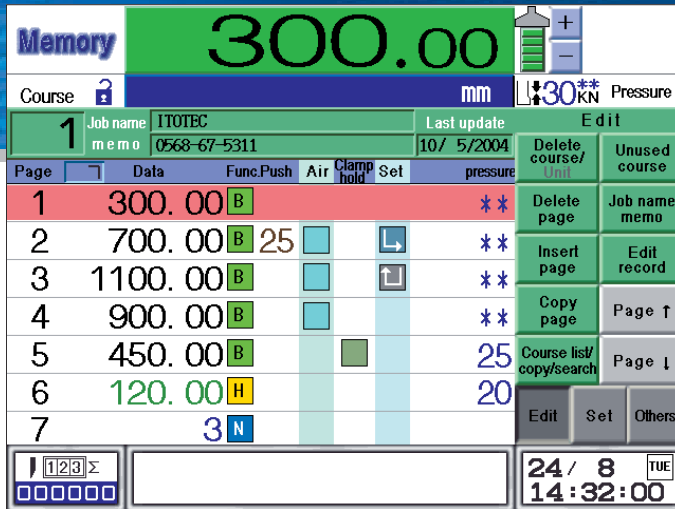

## LCD TOUCH PANEL

The touch panel type color LCD panel is of a light and easy-to-recognize TFT 8.4" type. Because seven pages are displayed at a time (center hold type scroll), course work description can be checked easily with reduced number of entry errors.

## CHARACTER ENTRY THROUGH KEYBOARD

A keyboard is displayed on the touch panel for character entry.



## COURSE LIST AND DETAILS

The used and empty course data for every 100 courses is displayed at the number panel. Further, course details show the job name and memo for every 10 courses, so that the description of the job can be searched for quickly. Movement and copy of courses can be made easily through operation at the number panel.

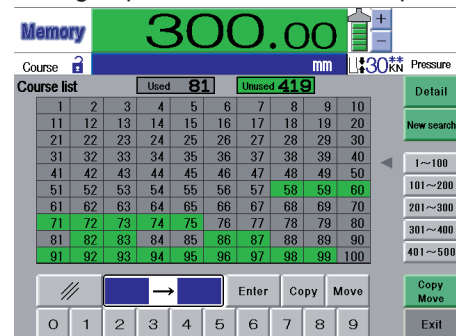

## INSERTION/DELETION OF MEMORY

Even after a job is memorized, any data can be inserted and/or deleted freely, excepting when plural jobs are memorized in the course.

## MESSAGE WINDOW AND ALARM FUNCTION

Knife change and oil change announcements are displayed with icons. The current state of the cutting machine is at a glance.

Various alarm functions notifying of the location and description of

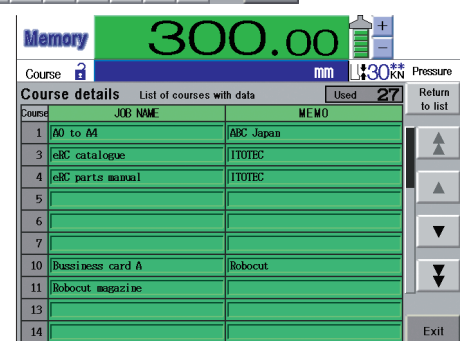

## PROGRAMMING IN 3 WAYS

1. Memorizing the cutting data through actual cutting jobs.
2. Memorizing the cutting data by Ten-Key buttons.
3. Memorizing the backgauge travelling data without both of knife acting and Ten-Key operation.



### PUSH OUT

For safe and efficient operation, the backgauge can be programmed to push out the paper stack after cutting and then to return to the next cutting position.

### STACKING OF PAPER

For easy stacking of large size sheets before the first cutting, the backgauge position for stacking can be programmed.

### AIR CUSHION CONTROL

Air cushion allows operator to program air on/off regardless of forward or backward movement of the backgauge.

### AIR EXPELLING FROM PAPER STACK

The backgauge stops automatically at the memorized position and the clamp descends to expel air from paper stack. Of course, the knife does not descend at that time.

### CLAMP TIMER

Set a delay in the ascent of the clamp to push the cut workpiece against the clamp and assort it easily.

### CLAMP PRESSURE

Set the clamp pressure for each course.

### CALCULATOR

The function of calculator is built-in and the result of calculations can be stored.

### METRIC/INCH CONVERSION

Conversion in inch fraction is also possible.

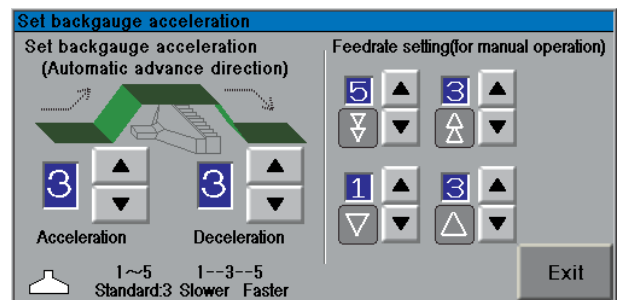

### BACKGAUGE ACCELERATION SETTING

Series of backgauge movements from the starting speed at the start of movement to deceleration and stop can be controlled as well as the speed. Best for prevention of workpiece collapse.

### BACKGAUGE MOTOR

AC servo motor is used for backgauge drive. So, free from the troublesome maintenance of carbon.

### READING OF BACKGAUGE POSITION

The pulse encoder of 2000 pulse reads out the exact position of backgauge. For example, it is possible to control the continuous movement of the backgauge in the minimum dimension of 0.01 mm or 0.001 inch continuously.

### DISPLAY OF BACKGAUGE POSITION

Backgauge position (cutting dimension) is displayed on the digital panel in the unit of 0.01 mm or 0.001 inch.

### CHANGE OF BACKGAUGE SPEED IN 5 STEPS

Backgauge speed can be changed by touch panel in 5 steps, which enables to select the most suitable speed according to the kind of jobs.



# STANDARD/OPTIONAL EQUIPMENT AND ACCESSORIES OF MODEL eRC

	100	115	137	160
Automatic star delta switch	○	○	○	○
Air cushion table	○	○	○	○
Chrome plated table	○	○	○	○
Shear bolts	○	○	○	○
Optical cutting line	○	○	○	○
False clamp plate	○	○	○	○
Slot closing tape	○	○	○	○
Cutting stroke counter	○	○	○	○
Knife changing device	○	○	○	○
Knife lifter by manual	△	△	△	△
Knife lifter by motor	△	△	△	△
Knife (SKH-2) 2 pcs.	○	○	○	○
Cutting stick 5 pcs.	○	○	○	○
Tool kit	○	○	○	○
Instruction manual	○	○	○	○
Operation manual	○	○	○	○
Cast-iron side table with air cushion 550×750 mm	○	○	○	△
Cast-iron side table with air cushion 650×950 mm	△	△	△	○

○ equipment △ optional

## UNLOADER **RU4.0 / RU4.1**

### Compact Yet It Conserves Energy For The Paper Unloading Process

The free lay-out system utilizes the limited space most effectively.

LCD with a touch panel simplifies operations for error displays and self-check or the like.



#### ● Design that places pallets on the floor

The unloader can be connected to any paper cutter and the design that places pallets on the floor eliminates the need for pit construction.

#### ● Easy operation

Change in paper size involves only one switch.

#### ● Self-check function

It checks that the safety sensor functions correctly upon start of operation to ensure safety.

#### ● Various settings

As the settings for the stack pressure and stack gap timer are digitally displayed, constant settings are available.

#### ● Error message function

When an error occurs, the location of the error, date and time of occurrence are shown as an error message and stored in the records.

## SPECIFICATIONS

	100		115		137		160	
Cutting width	40 1/2"	1030 mm	46"	1168 mm	54"	1370 mm	63"	1600 mm
Clamp opening	6 1/2"	165 mm	6 1/2"	165 mm	6 1/2"	165 mm	6 1/2"	165 mm
Cutting depth	39"	1000 mm	45 5/8"	1160 mm	52"	1320 mm	63"	1600 mm
Front table length	27 1/2"	650 mm	27 1/2"	700 mm	27 1/2"	700 mm	27 1/2"	700 mm
a. Table height	34 1/2"	875 mm	34 1/2"	875 mm	34 1/2"	875 mm	40 1/2"	890 mm
b. Table width	99 1/2"	2530 mm	105"	2668 mm	113"	2870 mm	137 3/4"	3500 mm
c. Machine width	90"	2285 mm	93 3/4"	2380 mm	103 1/2"	2630 mm	116 1/2"	2960 mm
d. Machine width(total)	104 3/4"	2660 mm	109 3/8"	2790 mm	118 1/2"	3010 mm	139 3/8"	3540 mm
e. Machine height	64 1/2"	1660 mm	65 1/3"	1660 mm	64 1/2"	1640 mm	72"	1730 mm
f. Machine length	96"	2440 mm	102 3/4"	2610 mm	108 1/2"	2760 mm	126 3/4"	3220 mm
Knife stroke	42"							
Clamp pressure	880-8800 lbs.	400-4000 daN	880-8800 lbs.	400-4000 daN	880-8800 lbs.	400-4000 daN	880-8800 lbs.	400-4000 daN
Net weight	7040 lbs.	3200 kg	9020 lbs.	4100 kg	9900 lbs.	4500 kg	13800 lbs.	5500 kg
Total power required	4.5 kw		5.2 kw		5.55 kw		7.4 kw	

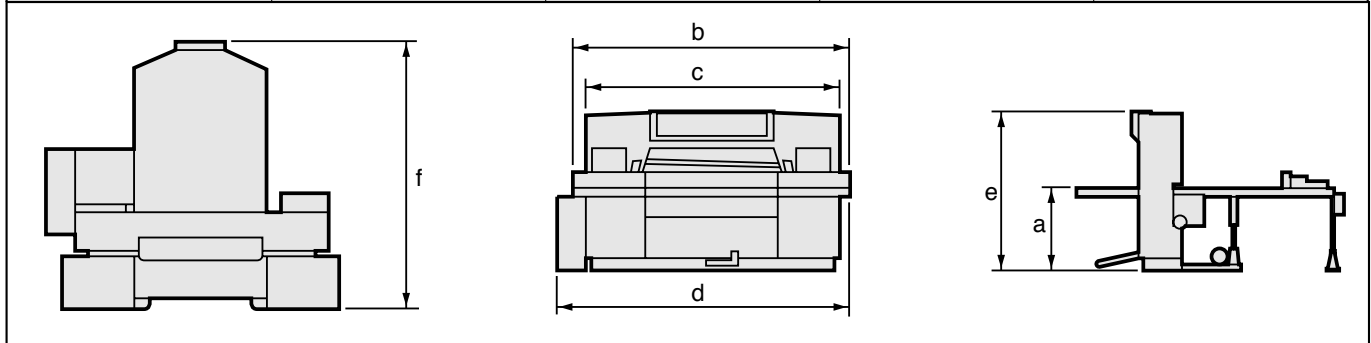

Designs and specifications are subject to change with/without notice.

## FLOOR PLAN FOR INSTALLATION

SIZE	A	B
100	2665 mm	2095 mm
115	2850 mm	2230 mm
137	3060 mm	2385 mm
160	3482 mm	3185 mm

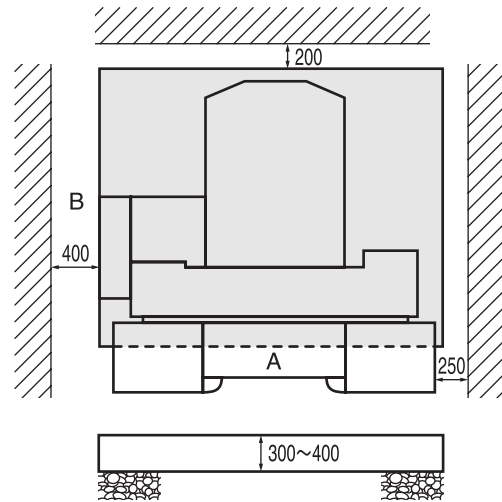

## KNIFE SIZE

SIZE	L	W	T	Bolts	Knife angle
100	1270 mm	150 mm	12.7 mm	12	21
115	1410 mm	150 mm	13.7 mm	13	21
137	1610 mm	150 mm	13.7 mm	15	21
160	1850 mm	165 mm	14.2 mm	16	21

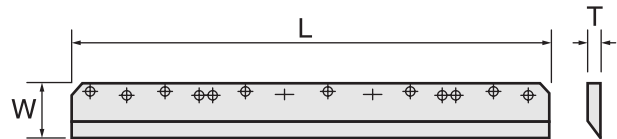

## STICK SIZE

SIZE	L
100	1055 mm
115	1193 mm
137	1395 mm
160	1623 mm

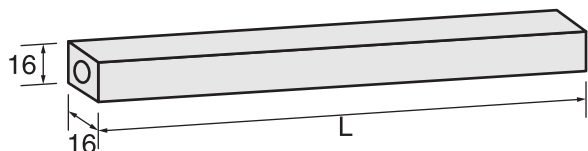

***www.itotec.co.jp***



**ITOTEC**

**ITOTEC CO.,LTD**

10-4 Funada, Inuyama, Aichi 484-0912, JAPAN.

Phone : 81-568-67-5311

Fax : 81-568-68-0495

URL <http://www.itotec.co.jp>

E-mail [export@itotec.co.jp](mailto:export@itotec.co.jp)

